

## Research Article

### Vaccination Readiness of COVID-19 and Generic Conspiracist Beliefs Among Young Adults: The Mediated Role of Health and Wellbeing

Bushra Naz,<sup>1</sup> Muhammad Kashif Fida,<sup>2</sup> Muhammad Zohaib Khan,<sup>3</sup> Azkaa Safdar,<sup>4</sup> Aqeel Asghar,<sup>5</sup>

<sup>1</sup>University of Central Punjab, Lahore; <sup>2</sup>Organizational Psychology & Development Department, Center for Assessment, Research and Employees' Evaluation (CARE), ABL - HOL, Lahore; <sup>3-5</sup>Department of Psychology, Government College University, Lahore

#### Abstract

**Background:** The significance and seriousness of COVID-19 vaccination are regarded as a public health emergency for national and international forums. Despite this fact, vaccination readiness is a challenge in young adults due to their belief in general conspiracy theories.

**Objective:** The prime objective of the study was to explore the relationship between vaccination readiness and generic conspiracist beliefs in young adults.

**Method:** A correlational research design was used to conduct this research study. A total sample of 185 young adults (male=83, female=102) aged (20-39 years) fulfilling the inclusion criteria were purposively recruited from different areas of Lahore, Pakistan. An online survey was conducted having demographic information form and standardized questions about vaccination readiness, generic conspiracist beliefs, and health and well-being. The link was sent to the participants through email, WhatsApp, Facebook, Twitter, LinkedIn, and other social media channels. During this survey participants recorded their responses in around ten weeks.

**Results:** Data were analyzed by utilizing SPSS-23 and AMOS-21. The results of correlation analysis revealed that vaccination readiness was inversely associated with generic conspiracist beliefs in young adults. Moreover, generic conspiracist beliefs have a significant negative impact on vaccination readiness. Health and well-being partially mediated the association between generic conspiracist beliefs and vaccination readiness.

**Conclusion:** The authorities should initiate awareness programs to enhance the readiness of the COVID-19 vaccination and also metastasize its effectiveness in young adults. Preventive measures should be taken to eradicate the elements that enhance the generic conspiracist beliefs about vaccination.

**Corresponding Author** | Bushra Naz, Assistant Professor, Department of Psychology, :University of Central Punjab, Lahore.

**Email:** nzbushra@gmail.com

**Keywords** | COVID-19, vaccination readiness, generic conspiracist beliefs, health and wellbeing.

#### Introduction

Vaccines are among the most groundbreaking modern medicine that is highly effective against infectious diseases like the latest COVID-19. In the vaccines approved by health organizations around the world,



#### Production and Hosting by KEMU

<https://doi.org/10.21649/akemu.v29i2.5506>  
2079-7192/© 2023 The Author(s). Published by Annals of KEMU on behalf of King Edward Medical University Lahore, Pakistan.  
This is an open access article under the CC BY4.0 license <http://creativecommons.org/licenses/by/4.0/>

their benefits supersede the potential risks. However, the vaccine often fails to completely eliminate the disease as vaccination rates are often too low to reach the critical threshold of herd immunity.<sup>1</sup>

It is generally assumed that the rate of vaccination in a population is dependent upon the availability, accessibility, and affordability of the vaccine. However, vaccination readiness, i.e., whether the population is ready and willing to take the vaccination, is another factor that affects the ratio of the vaccinated population.<sup>2</sup> There are seven identified components of vaccination readiness that will facilitate in effective intervention. These components are; (i) confidence – trust in the effectiveness and safety of the vaccine as well as the authorities developing or enforcing it, (ii) complacency – ignoring the vaccine due to a small perceived risk of the disease, (iii) constraints – structural or psychological hurdles in everyday life that make the vaccine costly or challenging, (iv) calculation – performing a personal cost and benefit analysis of the vaccine, (v) collective responsibility – an inclination to protect others and to eradicate the disease, (vi) compliance – supporting the societal monitoring and sanctioning of unvaccinated people, and (vii) conspiracy – believing the fake news related to the vaccine<sup>3</sup>. These factors may increase or decrease a person's likelihood of taking a vaccine.

The ongoing pandemic has further established that the conspiracy theories about vaccines are among the most endorsed and widespread of the medical conspiracy theories and that further lowers the intention to be vaccinated.<sup>4,5,6</sup> Conspiracy theory centers on the belief that multiple powerful actors are manipulating the events to accomplish their nefarious purposes, and this belief is usually supported by well-reasoned credible alternatives to the mainstream narrative. These alternatives become particularly enticing when an event has no definitive explanation or an authorized explanation seems inadequate.<sup>7,8</sup> Conspiracy theory beliefs are composed of five facets; (i) government malfeasance – believing in government misconduct and that government is responsible for crimes against its citizens, (ii) malevolent global conspiracies – believing that important events are being controlled by global elites, (iii) extraterrestrial cover-up – believing that the government is actively trying to hide extraterrestrial lifeforms, (iv) personal well-being – believing that the government

is intentionally spreading the disease or engaging in mind-control, and (v) control of information – suspecting that the government is hiding information from the masses.<sup>9</sup> Addressing whether people's reluctance to vaccinate is stemming from a belief in conspiracy theories is a vital step in taking necessary intervention steps.

During the COVID-19 pandemic, people's health and well-being have suffered a great deal whether it be due to the disruption in their daily routine, isolation, or the mental and financial toll of suffering through a pandemic.<sup>10,11</sup> A chance at being vaccinated has provided people with a hope that soon things will go back to the way they were. The majority of people are willing to get vaccinated if it means returning to the normal.<sup>12,13</sup> However, there is still a fraction of people, who despite the scientific claims, are apprehensive about vaccinations. This can be mainly attributed to the conspiracy theories and the fake news floating regarding COVID-19 and the vaccination.<sup>14,15</sup> Due to the uncertainty around the vaccination, the people believing such conspiracies are suffering.

This research was carried out to understand the individual differences in vaccination readiness and the components affecting this readiness, so that appropriate mitigating steps can be taken. Measuring vaccination readiness at a population level will allow the concerned authorities to identify the groups unwilling to vaccinate and the factors influencing them.

In the light of the given literature, the study was designed to achieve the following objectives:

1. To investigate the relationship between vaccination readiness, and generic conspiracist beliefs in young adults.
2. To determine the impact of generic conspiracist beliefs on vaccination readiness in young adults.
3. To explore the mediational role of health and well-being between the relationship of vaccination readiness and generic conspiracist beliefs among young adults.

The following research hypotheses were tested via statistical analyses:

**H<sub>1</sub>:** Vaccination readiness of COVID-19 would be negatively associated with generic conspiracist beliefs in young adults.

**H<sub>2</sub>:** There would be a significant impact of generic conspiracist beliefs on the vaccination readiness of young adults.

**H<sub>3</sub>:** Health and wellbeing would significantly mediate the relationship between generic vaccination readiness of COVID-19 and conspiracist beliefs.

## Methods

The cross-sectional research design was followed and employed a self-reported survey method for the data collection. The total sample comprised of (N=185) young adults including males (n=83) and females (n=102) with an age range from 20 to 39 (M=24.29, SD=2.93)(Table 1). Informed consent was obtained from the institution and the participants. The sampling was done with the help of convenience and snowball sampling techniques by following the inclusion/exclusion sample criteria (viz., inclusion criteria= age range between 18 to 40 years, education= bachelors and masters, exclusion criteria= old age participants and participants with any disability physical/psychological were not included). The sample was collected from different surroundings of Lahore (i.e., the central city of Lahore n=74, urbanized areas near the central city n=51, towns and suburbs n= 60). An online package of the questionnaires including demographic information was generated to collect the data. At the start of the questionnaire, the prime objectives of the study were defined clearly. Then, the questionnaire was sent to participants through their email and it was also shared with the targeted population on Facebook and WhatsApp groups. The participants were encouraged to refer the online survey link to their peers, relatives, friends, and coworkers. Referrals created the snowball effect and hence increased the proximity of data collection. ” In this online survey participants recorded their responses in the span from 11<sup>th</sup> May to 31<sup>st</sup> July 2021. Data collection through an online survey was relatively challenging as, during the initial two weeks of the execution, only 39 participants attempted the survey. Researchers followed up with the other remaining participants for data collection. Finally, the collected sample size reached the desired sample size for the study. Initially, the data of 223 participants were scrutinized and among them, 189 questionnaires were found complete in all aspects, furthermore, 04 question-

**Table 1:** Frequencies and Percentages of the Sample's Demographic Characteristics (N=185)

Demographics	n (%)
<b>Gender</b>	
Male	83 (44.9)
Female	102 (55.1)
<b>Education</b>	
Bachelors	110 (59.5)
Masters	75 (40.5)
<b>Have you contracted Covid 19?</b>	
Yes	39 (21.1)
No	146 (78.9)
<b>Has someone in your family contracted Covid 19?</b>	
Yes	82 (44.3)
No	103 (55.7)
<b>Do you personally know someone who has contracted Covid 19?</b>	
Yes	171 (92.4)
No	14 (7.6)
Age M(SD)	24.29 (2.93)

*Note: n= Number of Participants, %= Frequency of the Data, M(SD)= Mean (Standard Deviation)*

naires were also excluded from the study because of the indistinctness of their responses. Now, 82.95% data was ready for further investigations.

Vaccination Readiness Scale (7C) is comprised of a 21-items seven-point Likert-type rating scale ranging from (1 = “strongly disagree”, 7 = “strongly agree”). Seven subscales of this instrument measure different domains of vaccination readiness“(i.e., confidence= trust in security and effectiveness of the vaccination, calculation= “degree to which the personal cost and benefits of vaccination are weighted”, complacency = “laziness to get vaccinated due to low perceived risk of infectious disease, constraint=structural and psychological hurdles in daily life that make vaccination difficult or costly, collective responsibility= willingness to protect others and to eliminate infectious disease, compliance=support for societal monitoring and sanctioning of people who are not vaccinated, conspiracy = conspiracy thinking and belief in fake news related to vaccination).”The reported alpha reliability coefficient estimates are; for the overall vaccination readiness scale ( $\alpha=.88$ ), confidence ( $\alpha=0.69$ ), calculation ( $\alpha=.52$ ), complacency ( $\alpha=.50$ ), constraint ( $\alpha=.30$ ), collective responsibility ( $\alpha=.50$ ), compliance ( $\alpha=.60$ ), and conspiracy ( $\alpha=.45$ ).

Generic Conspiracist Belief Scale is consisting of fifteen items five-point Likert-type rating scale (1=definitely not true, 5=definitely true), having five sub-factors such as governmental malfeasance, extra-terrestrial cover-up, malevolent global conspiracy, personal wellbeing, and control of information. Each subfactor contained three items. The generic conspiracist beliefs can be measured by summing up all the subscales' totals. The overall reported reliability of the scale is ( $\alpha=.90$ ).

The Flourishing Scale was used to measure the health and well-being of young adults. The 8-item scale was designed to assess the physical, social and mental well-being of the individuals. It is a seven-point Likert-type rating scale ranging from (7=strongly agree, 1=strongly disagree). The reported alpha reliability for the scale is ranging from  $\alpha=.78$  to  $\alpha=.95$ .

Data was analyzed by using SPSS version-23 and AMOS version-21 and expressed as frequencies, mean, standard deviation (M, SD), and percentages. Parametric tests were applied to evaluate the significance of the results. Reliability analysis, correlation, and mediational analyses were used to evaluate the significance of the data. Moreover, data was compared and analyzed at a significance level of 0.05.

## Results

Reliability analyses indicated that all the research instruments have acceptable reliability coefficient estimates ( $\alpha$ ) (Table 2).

**Table 2:** Reliability Analysis of The Research Instruments and Their Sub-Scales (N=185)

Research Instruments	$\alpha$
<b>Vaccination Readiness</b>	0.75
Confidence*	0.80
Calculation*	0.61
Complacency*	0.77
Constraint*	0.60
Collective Responsibility*	0.70
Compliance*	0.64
Conspiracy*	0.73
<b>Generic Conspiracist Beliefs</b>	0.91
Governmental Malfeasance*	0.79
Extra-Terrestrial Cover-Up*	0.86
Malevolent Global Conspiracies*	0.78
Personal Wellbeing*	0.70
Control of Information*	0.69
<b>Health and Wellbeing</b>	0.89
Physical Wellbeing*	0.71
Social Wellbeing*	0.68
Mental Wellbeing*	0.77

*Note:  $\alpha$ = Cronbach's alpha Reliability, \*= Indicates the sub-scales of the instruments.*

Correlation analysis was conducted to explore the relationship between the variables and their sub-factors. Results indicated a significant negative relationship was found between the COVID-19 vaccination readiness and generic conspiracist beliefs (\*\* $p < .01$ ) among young adults. Likewise, the sub-factors of the variables also have positive and negative associations (\* $p < .05$ , \*\* $p < .01$ ) (Table 3).

**Table 3:** Relationship of Vaccination Readiness and Generic Conspiracist Beliefs in Young Adults (N=185)

Variables	1	2	3	4	5	6	7	8	9	10	11	12	13	14
1. Vaccination Readiness		.45**	.07	.79**	.76**	.58**	.57**	.55**	-.45**	-.44**	-.37**	-.33**	-.39**	-.28**
2. Confidence*			-.20*	.20**	.20**	.21**	.092	.21**	-.26**	-.26**	-.17*	-.17*	-.29**	-.16*
3. Calculation*				-.14	-.13	-.30**	-.15	.04	.09	.16*	.05	.04	.08	-.02
4. Complacency*					.74**	.46**	.37**	.30**	-.37**	-.39**	-.29**	-.26**	-.35**	-.26**
5. Constraint*						.48**	.36**	.26**	-.40**	-.41**	-.28**	-.30**	-.35**	-.27**
6. Collective Responsibility*							.39**	.09	-.28**	-.28**	-.28**	-.18*	-.22**	-.18*
7. Compliance*								.25**	-.19*	-.24**	-.18*	-.13	-.09	-.10
8. Conspiracy*									-.27**	-.26**	-.29**	-.22**	-.25**	-.08
9. Generic Conspiracist Beliefs										-.80**	.76**	.84**	.86**	.83**
10. Governmental Malfeasance*											-.50**	.66**	.56**	.53**
11. Extra-Terrestrial Cover-Up*												-.57**	.55**	.49**
12. Malevolent Global Conspiracies*													-.64**	.63**
13. Personal Wellbeing*														.75**
14. Control of Information*														

*Note. \*\* $p < .001$ , \* $p < .05$ , \*= Indicating the Subscales of the Bold Variables.*



Figure 1 demonstrated the significant ( $\beta = -.44, p < .01$ ) inverse direct impact of generic conspiracist beliefs with its predictors (i.e., Governmental Malfeasance, Extra-Terrestrial Cover-Up, Malevolent Global Conspiracies, Personal Wellbeing, and Control of Information) on vaccination readiness among young adults. The significant negative impact indicates that an increase in generic conspiracist beliefs decreases vaccination readiness in young adults.

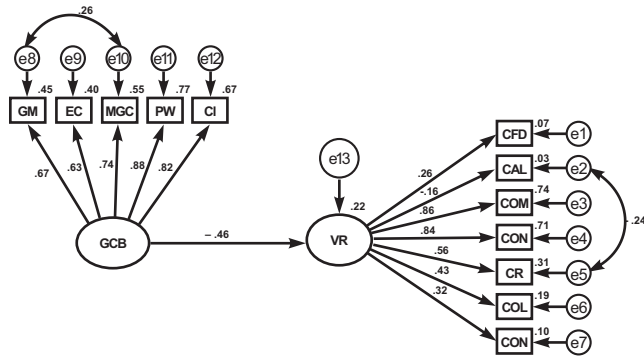

**Figure 1:** The Standardized Regression Path Coefficients for the Model and the Impact of Generic Conspiracist Beliefs on Vaccination Readiness in Young Adults.

**Note:** GM=Governmental Malfeasance, EC=Extra-Terrestrial Cover-Up, MGC=Malevolent Global Conspiracies, PW=Personal Wellbeing, CI=Control of Information, GCB=Generic

**Table 4:** Standardized Direct Effect Model Fit Indices of Generic Conspiracist Beliefs on Vaccination Readiness in Young Adults (N=185)

Model	$\chi^2$	df	CMIN	RMSEA	CFI	GFI	TLI
Model-Fit Indices	90.91	50	1.81	.06	.94	.91	.93

Note.  $**p < .001, *p < .05 = \text{CMIN/DF} < 3$ .

Conspiracist Beliefs, RV=Vaccination Readiness, CFD= Confidence, CAL=Calculation, COM=Complacency, CON=Constraint, CR=Collective Responsibility, COL=Compliance, CON=Conspiracy.”

The standardized model fit indices indicated that the model is well-fitted for the impact of generic conspiracist beliefs on vaccination readiness,  $\chi^2 = 90.91$  (df = 50, N=185),  $p < .05$ , RMSEA = .06, CFI = .94, GFI = .91 and TLI = .93 (Table-4). The value of chi-square is significant because of a greater degree of freedom, therefore by dividing the degree of freedom with chi-square ( $\chi^2/\text{df}$ ) the determined value is 1.81 which is acceptable for model fit.

**Step-1: Direct Impact of Generic Conspiracist Beliefs on Vaccination Readiness**

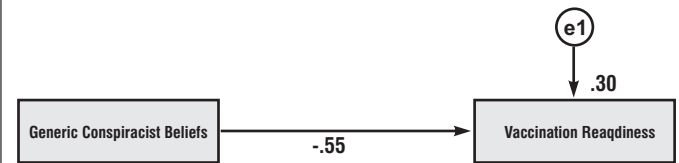

**Step-2 Indirect Impact of Generic Conspiracist Beliefs on Vaccination Readiness, Health and Wellbeing as a Mediator**

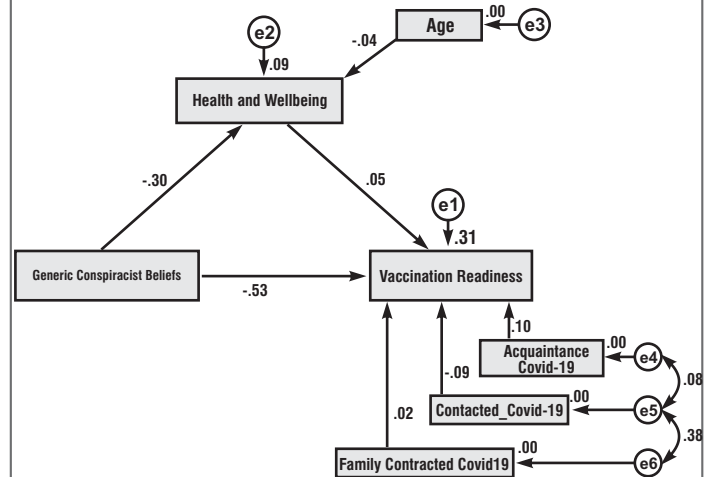

**Note:**  $**p < .01, *p < .05$ , Acquaintance COVID-19 = Do you personally know someone who has contracted COVID-19, Contracted COVID-19 = Have you contracted COVID-19, Family Contracted COVID-19 = Has someone in your family contracted COVID 19.”

**Figure 2:** Mediation Analysis: Health and Wellbeing as a Mediator between the Relationship of Generic Conspiracist Beliefs and Vaccination Readiness among Young Adults

Figure 2, step-1 illustrated the standardized significant direct effect of generic conspiracist beliefs on vaccination readiness ( $\beta = -.55, p < .01$ ). The step-2 showed the significant indirect path coefficient between generic conspiracist beliefs to vaccination readiness ( $\beta = -.53, p < .01$ ), after mediation of health and wellbeing. The health and wellbeing of the young adults significantly mediated the relationship of both variables. Although the covariates (i.e., age of the young adults, acquaintance COVID-19, contracted COVID-19, and family contracted COVID-19) have also an impact on the overall model. The mediation analysis has partitioned the total effect of generic conspiracist beliefs on the young adults’ vaccination readiness is  $c = -.54$ , into a

direct effect  $c = -.53$  and a mediated effect  $(-.30 \times .05) = -.0120$ . It means one standard deviation decrease in generic conspiracist beliefs brings an increase in vaccination readiness through the mediational effect of health and wellbeing.

**Table 5:** Standardized Mediation Model Fit Indices (N=185)

Model	$\chi^2$	df	CMIN	RMSEA	CFI	GFI	TLI
Model-Fit Indices	24.35	12	2.09	.07	.90	.91	.85

The standardized model fit indices indicated that the model is adequately fitted for the mediation between the relationship of generic conspiracist beliefs and vaccination readiness among the young adults,  $\chi^2 = 24.35$  (df = 12, N = 185), RMSEA = .07, CFI = .90, GFI = .91 and TLI = .85 (Table 5). The value of chi-square is significant because of the greater degree of freedom, therefore by dividing the degree of freedom with chi-square ( $\chi^2/df$ ) the determined value is 1.08 which is acceptable for model fit.

## Discussion

This study was conducted to assess the association and impact of generic conspiracist beliefs on the vaccination readiness of young adults. The results showed that the higher the conspiracist beliefs the less likely people are to vaccinate. These results correspond with the studies previously done on the topic.<sup>22,23,24</sup> The belief that COVID-19 is a part of some elaborate hoax to control the masses by either government or the influential individuals of the society is a barrier towards people's willingness to be vaccinated. Results have indicated that participants who believe that the vaccine is secure and effective, are willing to protect their fellow beings, and want to eliminate infectious diseases are less likely to fall prey to the conspiracy theories.

Results also depicted a partial mediation of health and wellbeing in the relationship between generic vaccination readiness of COVID-19 and conspiracist beliefs. This portrayed those individuals who are more cautious regarding their health and wellbeing are less likely to pay heed to conspiracy theories and are thus more willing to be vaccinated. The individual's inclination towards their health and wellbeing urges them to find ways to

maintain it and are thus more likely to research and agree on the effectiveness of vaccination.<sup>25</sup>

This study would be helpful for the National and Command Operation Center (NCO) government of Pakistan, medical doctors, researchers, and the common people of the society by highlighting the significance of COVID-19 vaccination in the domain of health and wellbeing including physical, social and mental wellbeing. Further, the obstructions among the young adults for vaccination readiness can be eliminated by vaccination awareness campaigns. These awareness campaigns can go a long way in enhancing vaccination readiness by removing the generic conspiracist beliefs.

It is a purely quantitative study; a qualitative exploration could also be made to identify the other culturally specific conspiracist beliefs. The sample could be recruited from various cities/provinces of Pakistan through a simple random sampling technique to enhance the generalizability of the study. Furthermore, a comparison group could also be made city/province-wise.

## Conclusion

The COVID-19 pandemic has been an extremely challenging time globally. It has forced people to not only deal with the apprehension of a debilitating disease but also with its financial and social ramifications. These uncertain times have allowed various alternate explanations to try and elucidate this global phenomenon. These alternate explanations can no longer be ignored as unhinged and far-fetched as more and more people are turning to them for clarification. The need of the hour is to understand these beliefs and explanations and the steps that can be taken by the mainstream media and governments to address people's trepidations. This research is a step towards this progress.

**Ethical Approval:** Given

**Conflict of Interest:** The authors declare no conflict of interest.

**Funding Source:** None

## References

1. Fang FC, Benson CA, Del Rio C, Edwards KM, Fowler Jr VG, Fredricks DN, et al. COVID-19 lessons learned and questions remaining. Arch. Clin. Infect. Dis. 2021;

- 72(12):2225-40.
2. Bohm R, Betsch C. Prosocial vaccination. *Curr Opin Psychol.* 2022; 43(1):307-11.
  3. Geiger M, Rees F, Lilleholt L, Santana AP, Zettler I, Wilhelm O, et al. Measuring the 7Cs of vaccination readiness. *Eur J Psychol Assess.* 2021; 1-9. <https://doi.org/10.1027/1015-5759/a000663>
  4. Hornsey MJ, Harris EA, Fielding KS. The psychological roots of anti-vaccination attitudes: A 24-nation investigation. *Health Psychol.* 2018; 37(4):307-15.
  5. Romer D, Jamieson KH. Conspiracy theories as barriers to controlling the spread of COVID-19 in the US. *Soc Sci Med.* 2020; 263(34):1133-56.
  6. Roozenbeek J, Schneider CR, Dryhurst S, Kerr J, Freeman AL, Recchia G, et al. Susceptibility to misinformation about COVID-19 around the world. *R. Soc. Open Sci.* 2020; 7(10):1-15.
  7. Miller JM. Psychological, political, and situational factors combine to boost COVID-19 conspiracy theory beliefs. *CJPS/RCSP.* 2020; 53(2):327-34.
  8. Knight P. Conspiracy, Complicity, Critique. *symploke.* 2021;29(1):197-215.
  9. Brotherton R, French CC, Pickering AD. Measuring belief in conspiracy theories: The generic conspiracist beliefs scale. *Front. Psychol.* 2013; 4(279):1-15.
  10. Lades LK, Laffan K, Daly M, Delaney L. Daily emotional well-being during the COVID-19 pandemic. *Br. J. Health Psychol.* 2020; 25(4): 902-11.
  11. O'Connor RC, Wetherall K, Cleare S, McClelland H, Melson AJ, Niedzwiedz CL, et al. Mental health and well-being during the COVID-19 pandemic: Longitudinal analyses of adults in the UK COVID-19 Mental Health & Wellbeing study. *Br J Psychiatry.* 2021; 218(6): 326-33.
  12. Kelly BJ, Southwell BG, McCormack LA, Bann CM, MacDonald PD, Frasier AM, et al. Predictors of willingness to get a COVID-19 vaccine in the US. *BMC Infectious Diseases.* 2021;21(1):1-7.
  13. Kessels R, Luyten J, Tubeuf S. Willingness to get vaccinated against Covid-19 and attitudes toward vaccination in general. *Vaccine.* 2021; 39(33):4716-22.
  14. Khan YH, Mallhi TH, Alotaibi NH, Alzarea AI, Alanazi AS, Tanveer N, et al. Threat of COVID-19 vaccine hesitancy in Pakistan: The need for measures to neutralize misleading narratives. *Am. J. Trop. Med.* 2020; 103(2):603-4.
  15. Ullah I, Khan KS, Tahir MJ, Ahmed A, Harapan H. Myths and conspiracy theories on vaccines and COVID-19: Potential effect on global vaccine refusals. *Vacunas.* 2021; 22(2):93-107.
  16. Emerson RW. Convenience sampling, random sampling, and snowball sampling: How does sampling affect the validity of research? *J Vis Impair Blind.* 2015; 109(2): 164-8.
  17. Egorova MS, Parshikova OV, Chertkova YD, Staroverov VM, Mitina OV. COVID-19: Belief in conspiracy theories and the need for quarantine. *Psychol. Russ.: State Art.* 2020;13(4):2-5.
  18. Howell AJ, Buro K. Measuring and predicting student well-being: Further evidence in support of the flourishing scale and the scale of positive and negative experiences. *Soc. Indic. Res.* 2015;121(3):903-15.
  19. Hu LT, Bentler PM, Kano Y. Can test statistics in covariance structure analysis be trusted? *Psychol. Bull.* 1992; 112: 351-62.
  20. Arbuckle J. Amos 17.0 user's guide. SPSS Inc.; 2008.
  21. Iftikhar R, Malik F. Translation and validation of Aggression Questionnaire in a Pakistani children cohort. *Pakistan J Soc Clin Psychol.* 2014; 12(1): 39-45.
  22. Earnshaw VA, Eaton LA, Kalichman SC, Brousseau NM, Hill EC, Fox AB. COVID-19 conspiracy beliefs, health behaviors, and policy support. *Transl. Behav. Med.* 2020;10(4): 850-6.
  23. Paul KT, Eberl JM, Partheymuller J. Policy-relevant attitudes toward COVID-19 vaccination: Associations with demography, health risk, and social and political factors. *Frontiers in public health.* 2021; 9(6):326-33.
  24. Freiman O. The Philosophy of Taking Conspiracy Theories Seriously. *Soc Epistemol.* 2019; 8(9): 51-61.
  25. Allington D, Duffy B, Wessely S, Dhavan N, Rubin J. Health-protective behaviour, social media usage and conspiracy belief during the COVID-19 public health emergency. *Psychol. Med.* 2021; 51(10):1763-9.